

YUEQING HONGYI ELECTRONICS CO., LTD
乐清市宏一电子有限公司

SPECIFICATION FOR APPROVAL

承认书

CUSTOMER 客户名称	
DESCRIPRION 产品名称	ZH1.5 系列连接器
ITEM NO 编 号	HY-A15002 (A27)
DATE 日 期	2022-09-03

CUSTOMER ACKNOWLEDGEMENT SEAL

客户承认印签

(APPROVAL) 核准	(ENGINEERING) 工程	(PURCHASE) 采购	(QUALITY) 品质
承认结果： <input type="checkbox"/> 通过 <input type="checkbox"/> 不通过 <input type="checkbox"/> 重新送样			

IS09001

IS014001

IS045001

IATF16949 体系认证

ADD: No. 30, Wenjing Road, Houyu village, Shifan street, Yueqing City, Zhejiang Province

地址：浙江省乐清市石帆街道后屿文景路 30 号

TEL:0577-62380521

FAX: 0577-62381979 P.C:325608

http: //www.zhehongyi.com

E-MAIL:yaohongxiao88@126.com

产 品 承 认 书 目 录

1、封面	1-1
2、修订履历	2-2
2、目录	3-3
3、技术规范	4-10
4、产品图纸	11-18

PRODUCT SPECIFICATION

产 品 规 范

1、Scope

适用范围

This specification includes the following specifications, including the specification of ZH series connector

本规范包括下列此种规格包括 ZH 系列连接器规格说明

2、Appearance and Dimension

外观及尺寸

2.1 Appearance:Product surface without defect、dirt、crack、and mechanical damang,Contactwithout rust,plating not oxidized and not peeled.

产品表面不应有对制品有害的缺陷、污垢、裂痕及机械损伤；接触件无锈蚀、镀层氧化脱落等现象

2.2 Dimension:According to drawings

外形尺寸：依照附图

3、Disposal of Material and surface

材料与表面处理

Specification 规格内容	Material 材 质	Finish 表面处理	Environmental protection grade 环保等级
Terminal 端 子	Phosphor bronze 锡青磷铜 厚 0.20mm	Tin Plating:2.5-5 μm 镀锡：2.5-5 μm	RoHS2.0
Housing 胶 壳	PA66 UL94V-0	Color: White 颜色：白色	
Wafer 直 针 座	Plastic 塑 壳	PA46/PBT UL94V-0 Color:White/Beige 颜色：白色/米色	
	Contact 插 针	Brass 黄铜 厚 φ 0.50mm Tin Plating:2.5~5 μm 镀锡：2.5~5 μm	
Wafer 弯 针 座	Plastic 塑 壳	PA46/PBT UL94V-0 Color:White/Beige 颜色：白色/米色	
	Contact 插 针	Brass 黄铜 厚 φ 0.50mm Tin Plating:2.5~5 μm 镀锡：2.5~5 μm	
Wafer 定位弯针 针座	Plastic 塑 壳	PA46 UL94V-0 Color: Beige 颜色：米色	
	Contact 插 针	Brass 黄铜 厚 φ 0.50mm Tin Plating:2.5~5 μm 镀锡：2.5~5 μm	
Wafer 卧贴/立 贴针座	Plastic 塑 壳	PA6T/LCP UL94V-0 Color: Beige 颜色：米色	
	Contact 插 针	Phosphor bronze 黄铜 厚 φ 0.50mm Tin Plating:2.5~5 μm 镀锡：2.5~5 μm	
	Solder tab 焊护耳	Brass 磷铜 厚 0.20mm Tin Plating:2.5~5 μm 镀锡：2.5~5 μm	

4、Ratings and applicable wires

额定等级

Item 项目	Standard 规格
Rated Voltage 额定电压	100V AC/DC
Rated Current 额定电流	1A AC/DC
Ambient temperature Range 使用温度范围	-25°C- +85°C
Applicable wire insulation 适用线径	AWG26#-32#

5、Electrical Performance

电气性能

N0. 序号	Ltem 项目	Test mode 试验方法	Requirement 技术要求
5.1	ContactResistance 接触电阻	Male female cooperation, open voltage less than 20mV, current 100mA detection connector at both ends 公母配合, 开放电压20mV 以下, 电流100mA 检测连接器连接器两端	Initial:20mΩ Max 初始: 20mΩ Max After Test: 30mΩ Max 试验后: 30mΩ Max
5.2	withstandvoltage 耐电压	Mate connectors, apply 500V AC for 1 minute between adjacent terminal or ground 公母配合, 在相邻端子, 端子与地片之间, 使用500V 的交流电1 分钟, 检测连接器	No Breakdown and Flashover 外观无损伤, 无打火花
5.3	InsulationResistance 绝缘电阻	Mate connectors, apply 500V DC between adjacent terminal or ground 公母配合, 在相邻端子, 端子与地片之间, 使用500V 的直流电, 检测连接器	500MΩ Min

6、机械性能

Mechanical Performance

NO. 序号	Ltem 项目	Test mode 试验方法	Requirement 技术要求								
6.1	Terminal crimping wire strength 端子压接导线强度	Fix the crimped terminal, apply axial pull out force on thewire 固定铆线后的端子, 使电线与端 子分离时所需的最小力量	<table border="1"> <tr> <td data-bbox="938 315 1139 439">AWG#26 wire AWG#26导线</td> <td data-bbox="1139 315 1465 439">More than 20N ≥20N</td> </tr> <tr> <td data-bbox="938 439 1139 562">AWG#28 wire AWG#28导线</td> <td data-bbox="1139 439 1465 562">More than 13N ≥13N</td> </tr> <tr> <td data-bbox="938 562 1139 685">AWG#30 wire AWG#30导线</td> <td data-bbox="1139 562 1465 685">More than 8N ≥8N</td> </tr> <tr> <td data-bbox="938 685 1139 792">AWG#32 wire AWG#32导线</td> <td data-bbox="1139 685 1465 792">More than 6N ≥6N</td> </tr> </table>	AWG#26 wire AWG#26导线	More than 20N ≥20N	AWG#28 wire AWG#28导线	More than 13N ≥13N	AWG#30 wire AWG#30导线	More than 8N ≥8N	AWG#32 wire AWG#32导线	More than 6N ≥6N
AWG#26 wire AWG#26导线	More than 20N ≥20N										
AWG#28 wire AWG#28导线	More than 13N ≥13N										
AWG#30 wire AWG#30导线	More than 8N ≥8N										
AWG#32 wire AWG#32导线	More than 6N ≥6N										
6.2	Terminal/ Housing Retention Force 端子保持力	Apply axial pull out force at the speed rate of 25.4±3mm/minute on the terminal assembled in the Housing 以每分25.4±3mm 的速率, 将端子从Housing 内轴 向拔出力	Per contact: 10N Min 单一接触点: 10N Min								
6.3	Insertion & withdraw Force 插拔力	Insert and withdraw Connectors at the speed rate of 25.4±3mm/minute 以每分钟 25.4±3mm 的速率插入和拔出	Refer to paragraph 8 参照第 8 项								
6.4	Pin Retention Force Pin 针保持力	Apply axial push force at the speed rate of 25.4±3mm/minute 以每分 25.4±3mm 的速率, 将 PIN 针从 Wafer 内轴向拔出力	Per contact: 10N Min 单一接触点: 10N Min								

7、Endurance Characteristics:

环境性能

NO. 序号	Ltem 项目	Test mode 试验方法	Requirement 技术要求	
7.1	Repeated Insertion/ Withdrawal 重复插拔	When mated up to 30 cycles repeatedly by the rate of 10 cycles per minute 以每分钟不超过 10 次的速率, 将公母插 拔 30 次	Contact Resistance 接触电阻	30 mΩ Max
7.2	Temperature Rise 温升测试	Mating connectors shall be energized at rating current until thermal stability is achieved, and then measured the temperature rise 公母连接器配合后, 加载额定电流直到温 度上升到稳定 状态, 然后再测量温升	Temperature Rise 温升测试	30℃ Max
7.3	Vibration test 振动测试	Amplitude: 1.5mm P-P Sweep time: 10~55~10 HZ in 1 minute Duration: 2 hours in each X.Y.Z axials 振幅: 1.5mm P-P 时间: 10~55~10 HZ in 1 minute 持续时间: 每轴向 2 小时	Appearance 外观	No damage 无异常
			Contact Resistance 接触电阻	30 mΩ Max
			Discontinuity 瞬断	1 micro- second Max.
7.4	Heat Resistance 耐热性	85±2℃,96 hours	Appearance 外观	No damage 无异常
			Contact Resistance 接触电阻	30 mΩ Max
7.5	Cold Resistance 耐寒性	-25±3℃,96 hours	Appearance 外观	No damage 无异常
			Contact Resistance 接触电阻	30 mΩ Max
7.6	Humidity 耐湿性	Temperature: 60±2℃ Relative Humidity: 90~95% Duration: 96 hours 温度: 60±2℃ 湿度: 90~95%(RH) 持续时间: 96 hours	Appearance 外观	No damage 无异常
			Contact Resistance 接触电阻	30 mΩ Max
			Withstand Voltage 耐电压	No Breakdown and Flashover 外观无损伤, 无打火花
			Insulation Resistance 绝缘电阻	500MΩ Min

NO. 序号	Ltem 项目	Test mode 试验方法	Requirement 技术要求	
7.7	温度变化 Temperature Cycling	5 cycles of: a) -25°C 30 minutes b) +85°C 30 minutes	Appearance 外观	No damage 无异常
		从-25°C持续30 分钟升至+85°C持续30 分钟,循环5 次	Contact Resistance 接触电阻	30 mΩ Max
7.8	Salt spray 盐雾	24±1 hours exposure to a salt spray from the 5±1% solution at 35±2°C	Appearance 外观	No damage 无异常
		在温度35±2°C, 盐水浓度5±1%下, 盐水 喷雾24±1 小时	Contact Resistance 接触电阻	30 mΩ Max
7.9	Solderability 焊锡附着性	Soldering Time: 3-5sec solder Temperature: 245±5°C 焊接时间: 3-5 秒 焊接温度: 245±5°C	Solder Wetting 焊料润湿	Immersion area above 95% 浸渍面积 95% 以上
7.10	Solder- Resistance 焊锡耐热性	<p>DIP type PBT material welding heat resistance range: Soldering time:3~5sec solder. Temperature:230±5°C DIP 型 PA66 材质焊接耐热范围: 焊接时间: 3~5 秒. 焊接温度: 230±5°C</p> <p>DIP type PA46 material welding heat resistance range: Soldering time:3~5sec solder. Temperature:245±5°C DIP 型 PA46 材质焊接耐热范围: 焊接时间: 3~5 秒. 焊接温度: 245±5°C</p> <p>SMT reflow soldering heat resistance range: Soldering time:5~10sec solder. Temperature:255±5°C SMT 型回流焊接耐热范围: 焊接时间: 5~10 秒. 焊接温度: 255±5°C</p> <p>Please refer to the 9.1 solder reflow temperature curve 回流焊请参考 9.1 温度曲线图</p>	Appearance 外观	No damage 无异常

8、INSERTION/WITHDRAWAL FORCE

综合插入力及拔出力

No. of CTK PIN 数	At Initial 初始值		At 30th 插拔 30 次	No. of CTK PIN 数	At Initial 初始值		At 30th 插拔 30 次
	I. F (N Max) 插入力	W. F (N Min) 拔出力	W. F (N Min) 拔出力		I. F (N Max) 插入力	W. F (N Min) 拔出力	W. F (N Min) 拔出力
2	25	4	2	12	75	12	10
3	30	5	3	13	80	12	11
4	35	6	3	14	85	14	12
5	40	7	4	15	90	14	12
6	45	8	5	16	95	16	14
7	50	8	6	17	100	16	14
8	55	9	7	18	105	18	16
9	60	9	7	19	110	18	16
10	65	10	8	20	115	20	18
11	70	10	9				

9、 SMT lead-free process temperature curve SMT 无铅工艺温度曲线

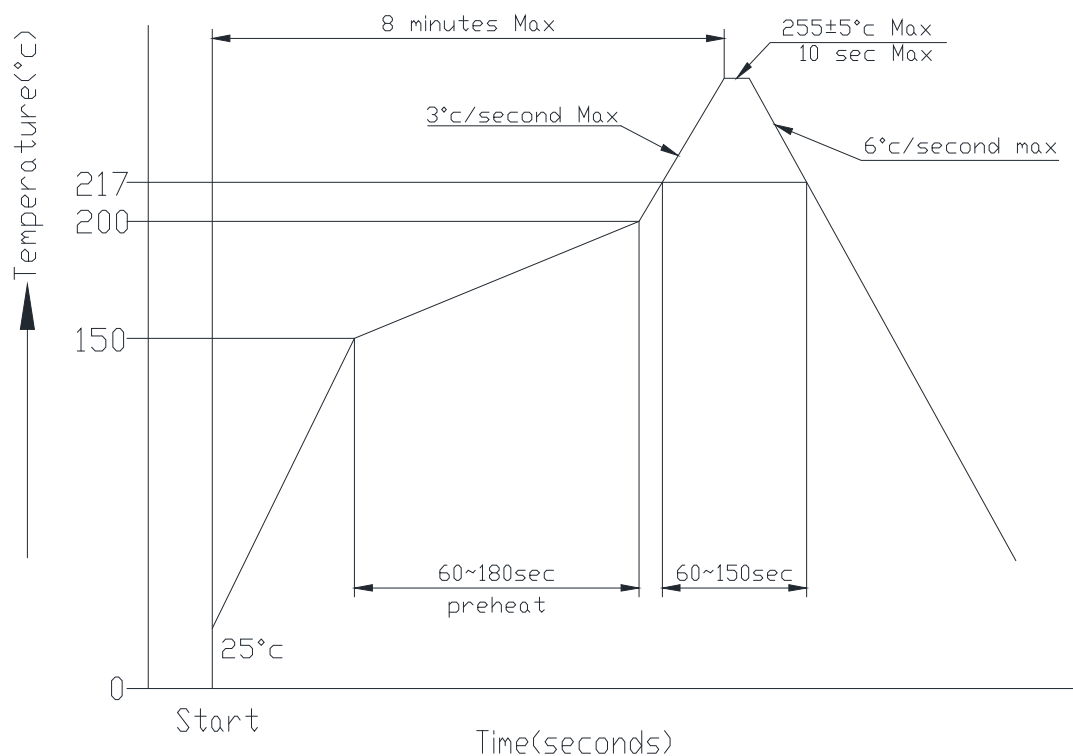

Notes: Please check the reflow soldering condition by your own devices beforehand. Because the condition changes by the soldering devices, P.C. boards, and so on

注记: 由于 P.C 板等焊接装置改变条件,所以请预先用自己的装置检查回流焊的条件

10、 Caution 注意事项

plastic because of characteristics with water after package is opened should avoid exposure to, the temperature is higher than 30 °C, humidity is higher than 60%RH in the environment, and in the 24 hours after all after use, to prevent subsequent reflow, wave soldering process to produce foaming phenomenon of deformation

塑料因具有吸水之特性包装拆封后应避免暴露于, 温度高于 30°C, 湿度高于 60%RH 的环境中, 并在拆封后 24 小时内全数使用完毕, 防止后续回流焊、波峰焊制程产生起泡变形现象

REV.	日期	ECN NO.	变更内容	制图
DATE	DESCRIPTION	DRAWN		

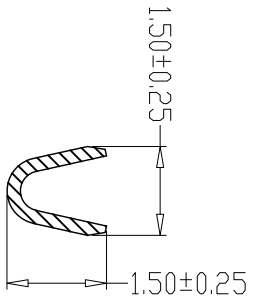
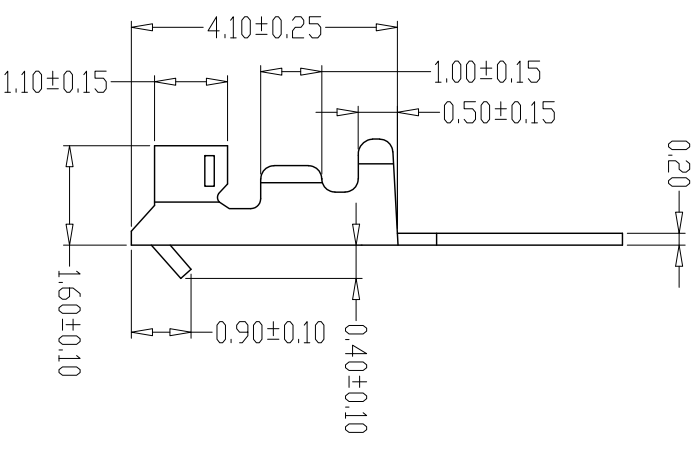
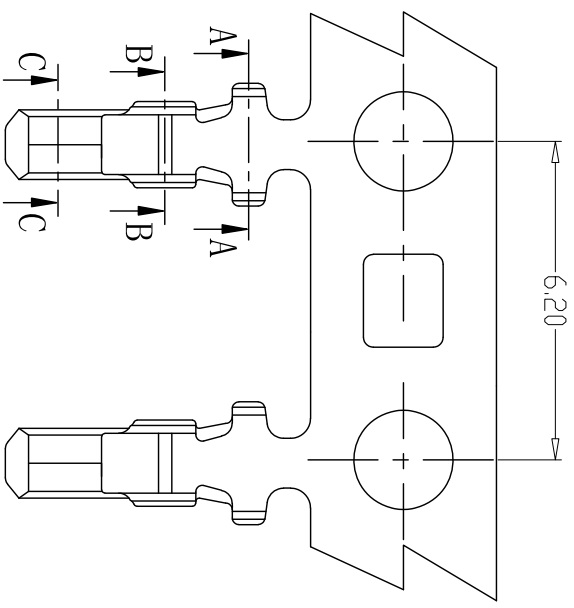

SEC:A-A

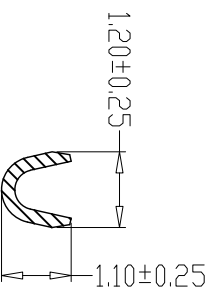

SEC:B-B

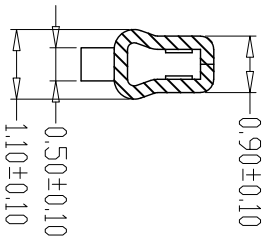

SEC:C-C

SPECIFICATIONS

- 1、Current Rating: 1A AC, DC
- 2、Voltage Rating: 100V AC, DC
- 3、Temperature Range: -25°C~+85°C
- 4、Contact Resistance: 20mΩ Max
- 5、Insulation Resistance: 500MΩ Min
- 6、Withstanding Voltage: 500V AC/minute
- 7、Material: Phosphoric bronze Tin-plated
- 8、Applicable Wire Sizes: AWG#26~32#

GENERAL TOLERANCE		制图	张迎春	料号	A15002-T	版本	A
X \pm 0.25	X \pm 2°	Mapping	2022. 09. 02	PART NO.		REV.	
X \pm 0.25	X \pm 1°	审核	钱岳生	品名	ZHL. 5端子	页次	1/1
.XX \pm 0.15	.XX \pm 0.5°	核准	张名	客户料号		SHEET	
.XXX \pm 0.10	.XXX \pm 0.5°	Approved	2022. 09. 03	CITM. NO.			
		单位	mm	比例			
		Units	SCALE				

乐清市宏一电子有限公司
YueQing HongYi Electronics Co., Ltd

REV.	日期	ECN NO.	变更内容	制图
DATE	DESCRIPTION	DRAWN		

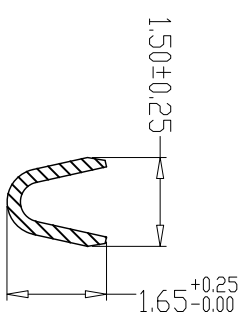
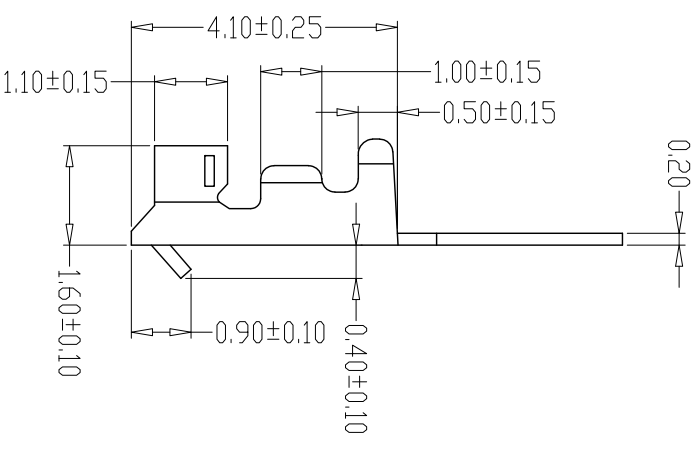
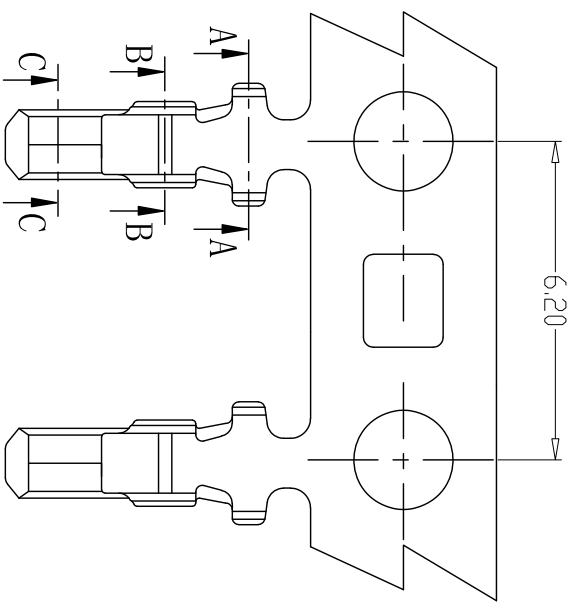

SEC:A-A

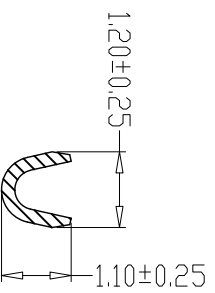

SEC:B-B

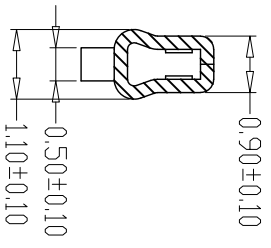

SEC:C-C

- SPECIFICATIONS**
- 1、Current Rating: 1A AC, DC
 - 2、Voltage Rating: 100V AC, DC
 - 3、Temperature Range: -25°C~+85°C
 - 4、Contact Resistance: 20mΩ Max
 - 5、Insulation Resistance: 500MΩ Min
 - 6、Withstanding Voltage: 500V AC/minute
 - 7、Material: Phosphoric bronze Tin-plated
 - 8、Applicable Wire Sizes: AWG#26~32#

GENERAL TOLERANCE		制图	张迎春	料号	A15002-T	版本	A
X \pm 0.25	X \pm 2°	Mapping	2022. 09. 02	PART NO.		REV.	
X \pm 0.25	X \pm 1°	审核	钱岳生	品名	ZH1.5端子(高脚)	页次	1/1
.XX \pm 0.15	.XX \pm 0.5°	Approved	2022. 09. 02	客户料号		SHEET	
.XXX \pm 0.10	.XXX \pm 0.5°	单位	2022. 09. 03	CITM. NO.			
		Units	mm	比例			
		SCALE					

乐清市宏一电子有限公司
YueQing HongYi Electronics Co., Ltd

REV.	日期	ECN NO.	变更内容	制图
	DATE		DESCRIPTION	DRAWN

- SPECIFICATIONS
- 1、Current Rating: 1A AC, DC
 - 2、Voltage Rating: 100V AC, DC
 - 3、Temperature Range: -25°C~+85°C
 - 4、Contact Resistance: 20mΩ Max
 - 5、Insulation Resistance: 500MΩ Min
 - 6、Withstanding Voltage: 500V AC/minute
 - 7、Material:Housing:PA66, UL94V-0

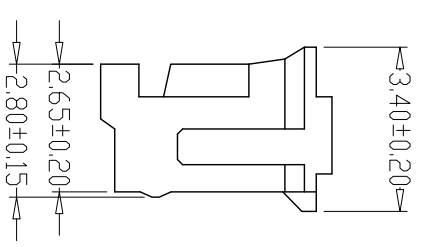
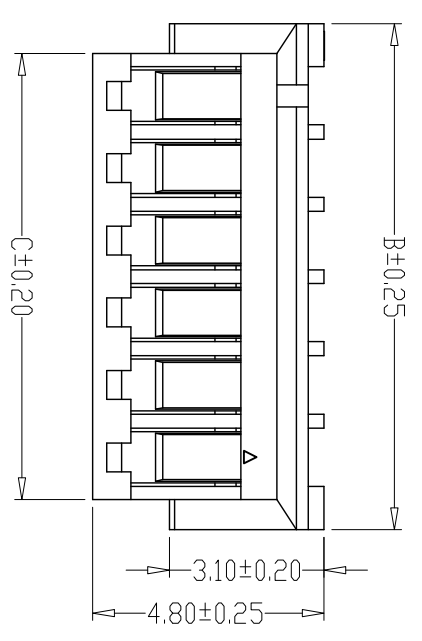
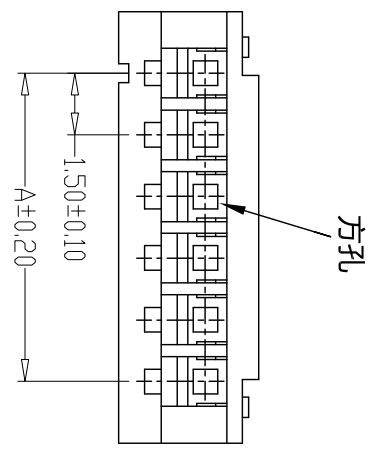
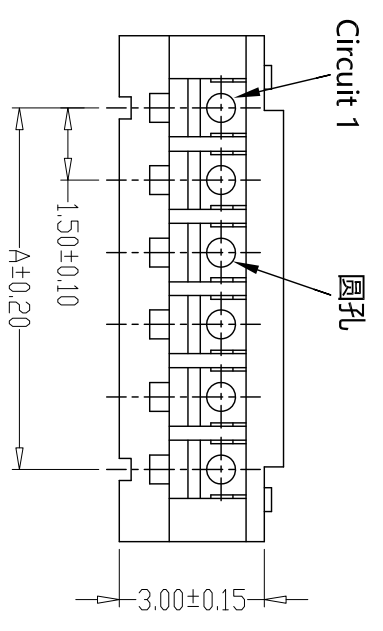

PIN	尺寸 (mm)		
	A	B	C
-02Y	1.50	4.50	3.30
-03Y	3.00	6.00	4.80
-04Y	4.50	7.50	6.30
-05Y	6.00	9.00	7.80
-06Y	7.50	10.50	9.30
-07Y	9.00	12.00	10.80
-08Y	10.50	13.50	12.30
-09Y	12.00	15.00	13.80
-10Y	13.50	16.50	15.30
-11Y	15.00	18.00	16.80
-12Y	16.50	19.50	18.30
-13Y	18.00	21.00	19.80
-14Y	19.50	22.50	21.30
-15Y	21.00	24.00	22.80
-16Y	22.50	25.50	24.30
-17Y	24.00	27.00	25.80
-18Y	25.50	28.50	27.30
-19Y	27.00	30.00	28.80
-20Y	28.50	31.50	30.30

GENERAL TOLERANCE		制图 Mapping	
X \pm 0.25	X $^{\circ}$ \pm 2 $^{\circ}$	2022、09、02	张迎春
X \pm 0.25	X $^{\circ}$ \pm 1 $^{\circ}$	审核 Audit	钱岳生
XX \pm 0.15	XX $^{\circ}$ \pm 0.5 $^{\circ}$	批准 Approved	张名
XXX \pm 0.10	XXX $^{\circ}$ \pm 0.5 $^{\circ}$	单位 Units	2022、09、03
		mm	比例 SCALE

料号 PART NO. A15002-1NY
 品名 TITLE ZH1.5孔座
 客户料号 CUST. NO.
 版本 REV. A
 页次 SHEET 1/1
 YueDing HongYi Electronics Co., Ltd

版本 REV.	日期 DATE	ECN NO.	变更内容 DESCRIPTION	制图 DRAWN

SPECIFICATIONS

- 1、Current Rating: 1A AC, DC
- 2、Voltage Rating: 100V AC, DC
- 3、Temperature Range: -25°C~+85°C
- 4、Contact Resistance: 20mΩ Max
- 5、Insulation Resistance: 500MΩ Min
- 6、Withstanding Voltage: 500V AC/minute
- 7、Material: Wafer PBT/PA46 White/Beige, UL94V-0
PIN Brass Tin-plated

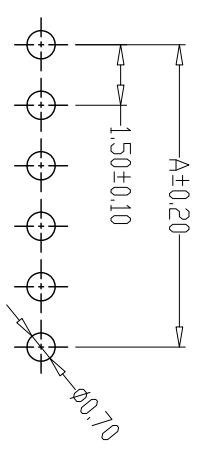
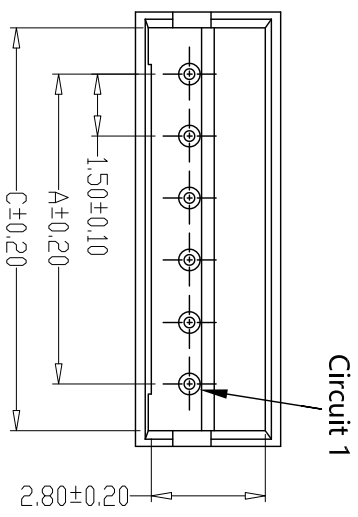

PCB LAYOUT

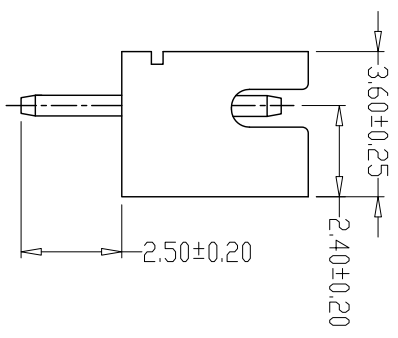
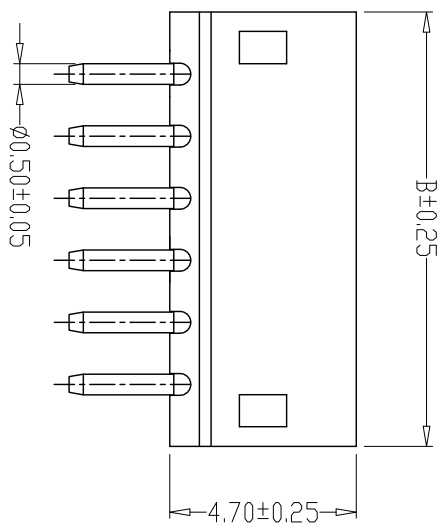

PIN	尺寸 (mm)		
	A	B	C
-02A	1.50	4.50	3.70
-03A	3.00	6.00	5.20
-04A	4.50	7.50	6.70
-05A	6.00	9.00	8.20
-06A	7.50	10.50	9.70
-07A	9.00	12.00	11.20
-08A	10.50	13.50	12.70
-09A	12.00	15.00	14.20
-10A	13.50	16.50	15.70
-11A	15.00	18.00	17.20
-12A	16.50	19.50	18.70
-13A	18.00	21.00	20.20
-14A	19.50	22.50	21.70
-15A	21.00	24.00	23.20
-16A	22.50	25.50	24.70
-17A	24.00	27.00	26.20
-18A	25.50	28.50	27.70
-19A	27.00	30.00	29.20
-20A	28.50	31.50	30.70

GENERAL TOLERANCE		制图 Mapping	
X \pm 0.25	X \pm 2°	2022. 09. 02	张迎春
X \pm 0.25	X \pm 1°	审核 Audit	钱岳生
.XX \pm 0.15	.XX \pm 0.5°	批准 Approved	张名
.XXX \pm 0.10	.XXX \pm 0.5°	单位 Units	2022. 09. 03
		mm	比例 SCALE

料号 PART NO.	A15002-nA	版本 REV.	A
品名 TITLE	ZH1.5直针	页次 SHEET	1/1
客户料号 CUSTOMER NO.	WAFER DIP TYPE		
YueDing HongYi Electronics Co., Ltd			

版本 REV.	日期 DATE	ECN NO.	变更内容 DESCRIPTION	制图 DRAWN

SPECIFICATIONS

- 1、Current Rating: 1A AC, DC
- 2、Voltage Rating: 100V AC, DC
- 3、Temperature Range: -25°C~+85°C
- 4、Contact Resistance: 20mΩ Max
- 5、Insulation Resistance: 500MΩ Min
- 6、Withstanding Voltage: 500V AC/minute
- 7、Material: Wafer PBT/PA46 White/Beige, UL94V-0
PIN Brass Tin-plated

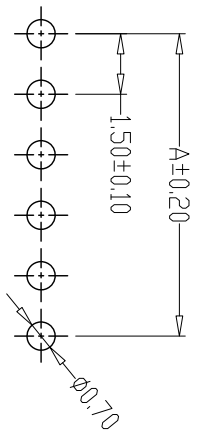
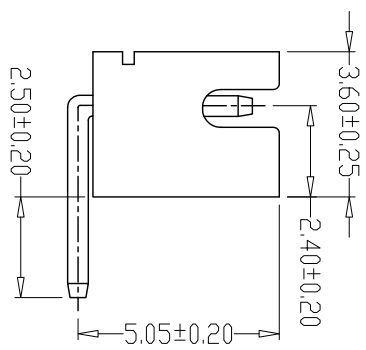
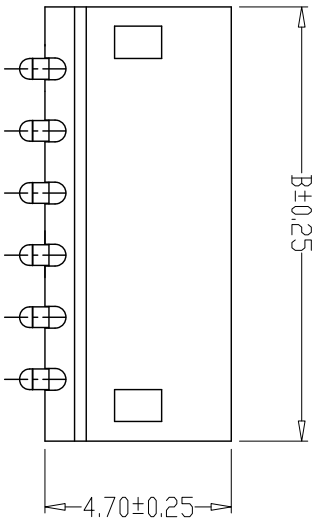
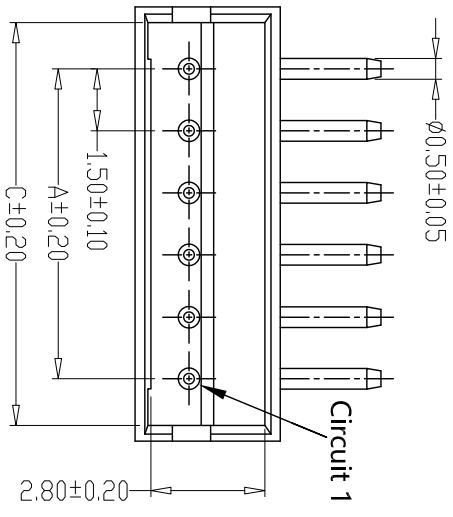

PCB LAYOUT

PIN	尺寸 (mm)		
	A	B	C
-02AW	1.50	4.50	3.70
-03AW	3.00	6.00	5.20
-04AW	4.50	7.50	6.70
-05AW	6.00	9.00	8.20
-06AW	7.50	10.50	9.70
-07AW	9.00	12.00	11.20
-08AW	10.50	13.50	12.70
-09AW	12.00	15.00	14.20
-10AW	13.50	16.50	15.70
-11AW	15.00	18.00	17.20
-12AW	16.50	19.50	18.70
-13AW	18.00	21.00	20.20
-14AW	19.50	22.50	21.70
-15AW	21.00	24.00	23.20
-16AW	22.50	25.50	24.70
-17AW	24.00	27.00	26.20
-18AW	25.50	28.50	27.70
-19AW	27.00	30.00	29.20
-20AW	28.50	31.50	30.70

GENERAL TOLERANCE		制图 Mapping	张迎春
X \pm 0.25	X \pm 2°	审核	钱岳生
X \pm 0.25	X \pm 1°	批准	张名
XX \pm 0.15	XX \pm 0.5°	Approved	2022.09.03
XXX \pm 0.10	XXX \pm 0.5°	单位 Units	mm
		比例 SCALE	7

料号 PART NO. A15002-1AW
 品名 品名 ZH1.5弯针
 TITLE WAFER DIP TYPE
 客户料号
 CIRM. NO.

版本 REV. A
 页次 SHEET 1/1

YueDing HongYi Electronics Co., Ltd

版本 REV.	日期 DATE	ECN NO.	变更内容 DESCRIPTION	制图 DRAWN
------------	------------	---------	---------------------	-------------

SPECIFICATIONS

- 1、Current Rating: 1A AC, DC
- 2、Voltage Rating: 100V AC, DC
- 3、Temperature Range: -25°C~+85°C
- 4、Contact Resistance: 20mΩ Max
- 5、Insulation Resistance: 500MΩ Min
- 6、Withstanding Voltage: 500V AC/minute
- 7、Material: Wafer PA46 Beige, UL94V-0
PIN Brass Tin-plated

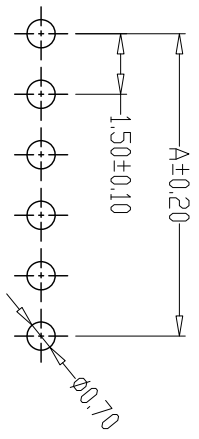
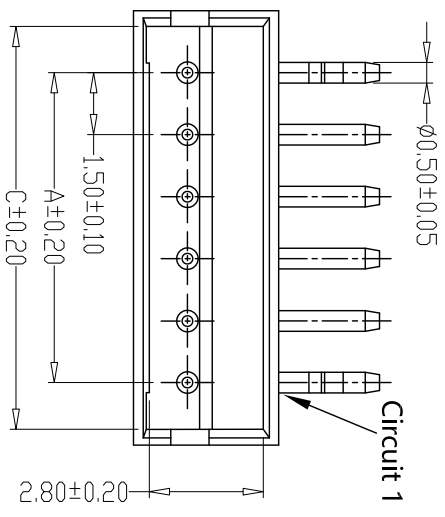

PCB LAYOUT

PIN	尺寸 (mm)		
	A	B	C
-02AWD	1.50	4.50	3.70
-03AWD	3.00	6.00	5.20
-04AWD	4.50	7.50	6.70
-05AWD	6.00	9.00	8.20
-06AWD	7.50	10.50	9.70
-07AWD	9.00	12.00	11.20
-08AWD	10.50	13.50	12.70
-09AWD	12.00	15.00	14.20
-10AWD	13.50	16.50	15.70
-11AWD	15.00	18.00	17.20
-12AWD	16.50	19.50	18.70
-13AWD	18.00	21.00	20.20
-14AWD	19.50	22.50	21.70
-15AWD	21.00	24.00	23.20
-16AWD	22.50	25.50	24.70
-17AWD	24.00	27.00	26.20
-18AWD	25.50	28.50	27.70
-19AWD	27.00	30.00	29.20
-20AWD	28.50	31.50	30.70

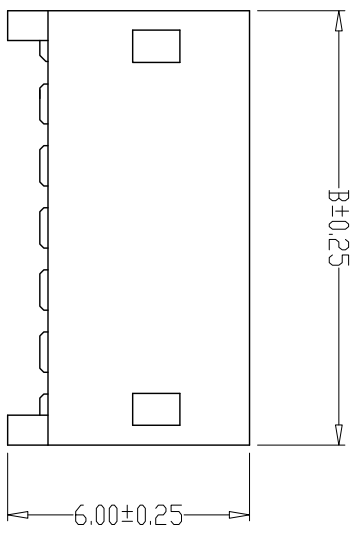
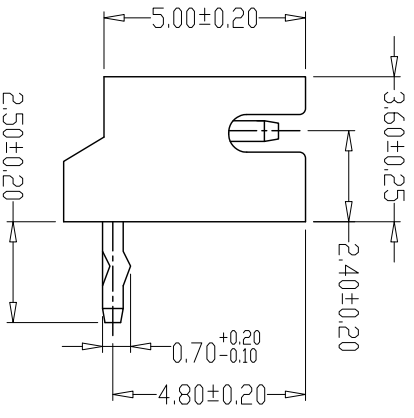

GENERAL TOLERANCE		制图 Mapping	张迎春
X \pm 0.25	X \pm 2°	审核 Audit	钱岳生
X \pm 0.25	X \pm 1°	批准 Approved	张名
.XX \pm 0.15	.XX \pm 0.5°	单位 Units	2022.09.03
.XXX \pm 0.10	.XXX \pm 0.5°	mm	比例 SCALE

料号 PART NO.	A15002-nAWD	版本 REV.	A
品名 TITLE	ZH1.5定位弯针	页次 SHEET	1/1
客户料号 CUST. NO.	WAFER DIP TYPE		

乐清市宏一电子有限公司
YueDing HongYi Electronics Co., Ltd

REV.	日期	ECN NO.	变更内容	制图
	DATE		DESCRIPTION	DRAWN

SPECIFICATIONS

- 1、Current Rating: 1A AC, DC
 - 2、Voltage Rating: 100V AC, DC
 - 3、Temperature Range: -25°C~+85°C
 - 4、Contact Resistance: 20mΩ Max
 - 5、Insulation Resistance: 500MΩ Min
 - 6、Withstanding Voltage: 500V AC/minute
 - 7、Material: Wafer PA6T, UL94V-0
- PIN Brass Tin-plated
Solder tad Phosphoric copper Tin-plated

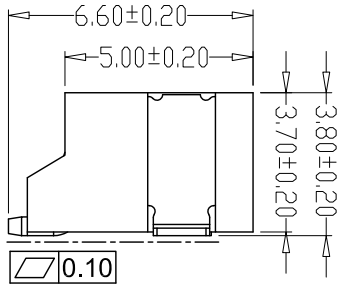
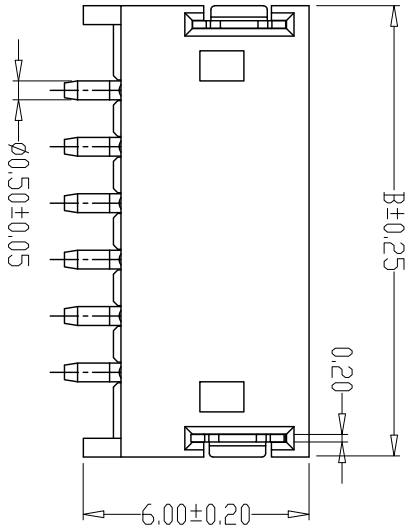
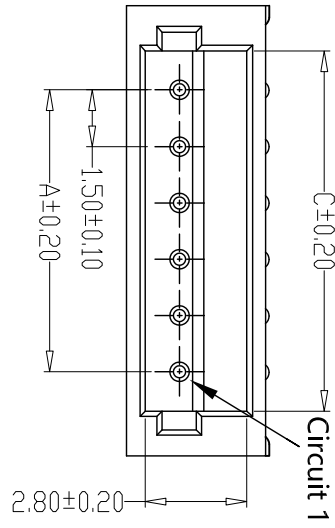
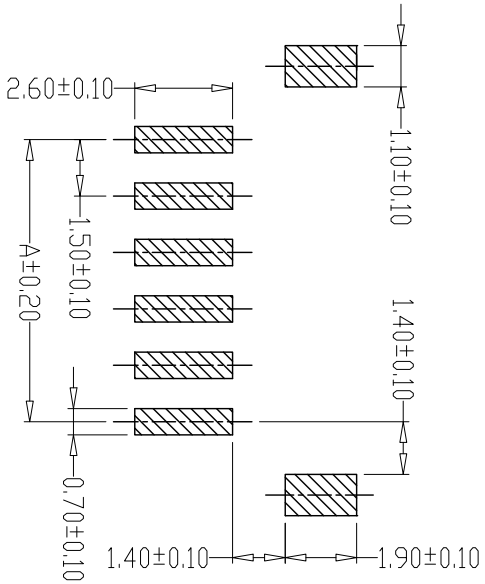

PCB LAYOUT

PIN	尺寸 (mm)		
	A	B	C
-02AWB	1.50	6.00	3.70
-03AWB	3.00	7.50	5.20
-04AWB	4.50	9.00	6.70
-05AWB	6.00	10.50	8.20
-06AWB	7.50	12.00	9.70
-07AWB	9.00	13.50	11.20
-08AWB	10.50	15.00	12.70
-09AWB	12.00	16.50	14.20
-10AWB	13.50	18.00	15.70
-11AWB	15.00	19.50	17.20
-12AWB	16.50	21.00	18.70
-13AWB	18.00	22.50	20.20
-14AWB	19.50	24.00	21.70
-15AWB	21.00	25.50	23.20
-16AWB	22.50	27.00	24.70
-17AWB	24.00	28.50	26.20
-18AWB	25.50	30.00	27.70
-19AWB	27.00	31.50	29.20
-20AWB	28.50	33.00	30.70

GENERAL TOLERANCE		制图	
X ₁ ±0.25	X ₂ ±2°	Mapping	张迎春
X ₃ ±0.25	X ₄ ±1°	审核	钱岳生
X ₅ ±0.15	X ₆ ±0.5°	批准	张名
XXX±0.10	XXX±0.5°	Approved	2022、09、03
Units	mm	比例	SCALE

料号: A15002-nAWB
 PART NO.
 品名: ZH1.5脚贴片
 TITLE: WAFER SMT TYPE
 客户料号: _____
 CUST. NO. _____

版本: A
 REV. _____

页次: 1/1
 SHEET _____

乐清市宏一电子有限公司
 YueDing HongYi Electronics Co., Ltd

REV.	日期	ECN NO.	变更内容	制图
	DATE		DESCRIPTION	DRAWN

SPECIFICATIONS

- 1、Current Ratings: 1A AC, DC
 - 2、Voltage Rating: 100V AC, DC
 - 3、Temperature Range: -25°C~+85°C
 - 4、Contact Resistance: 20mΩ Max
 - 5、Insulation Resistance: 500MΩ Min
 - 6、Withstanding Voltage: 500V AC/minute
 - 7、Material: Wafer PA6T, UL94V-0
- PIN Brass Tin-plated
Solder tad Phosphoric copper Tin-plated

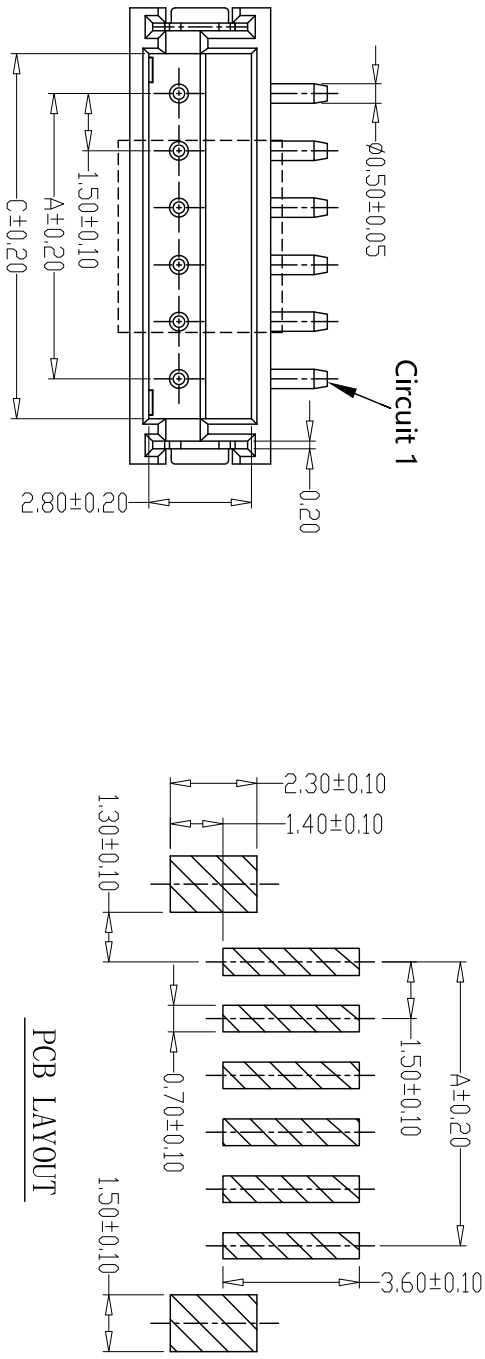

PCB LAYOUT

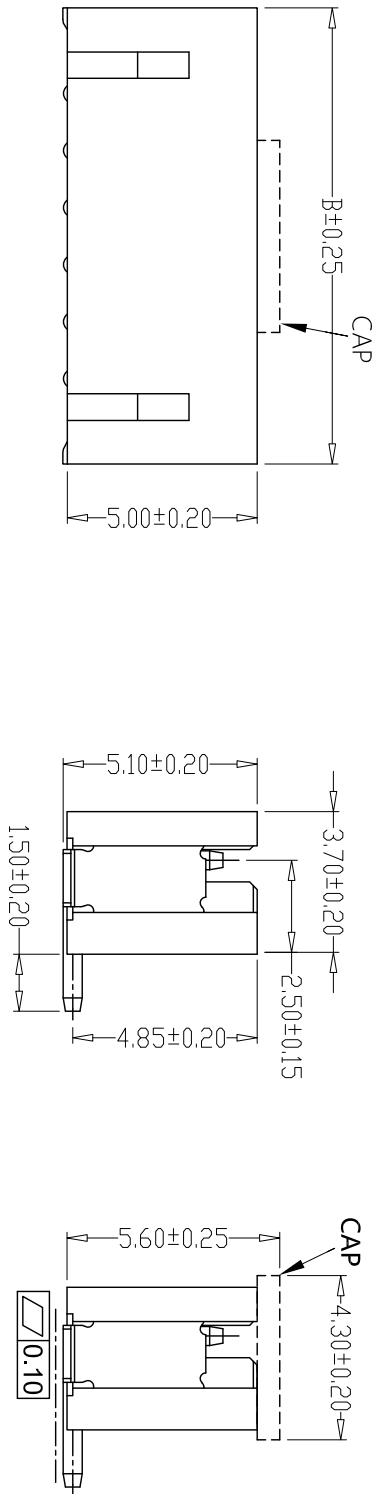

PIN	尺寸 (mm)		
	A	B	C
-02AB	1.50	6.00	3.70
-03AB	3.00	7.50	5.20
-04AB	4.50	9.00	6.70
-05AB	6.00	10.50	8.20
-06AB	7.50	12.00	9.70
-07AB	9.00	13.50	11.20
-08AB	10.50	15.00	12.70
-09AB	12.00	16.50	14.20
-10AB	13.50	18.00	15.70
-11AB	15.00	19.50	17.20
-12AB	16.50	21.00	18.70
-13AB	18.00	22.50	20.20
-14AB	19.50	24.00	21.70
-15AB	21.00	25.50	23.20
-16AB	22.50	27.00	24.70
-17AB	24.00	28.50	26.20
-18AB	25.50	30.00	27.70
-19AB	27.00	31.50	29.20
-20AB	28.50	33.00	30.70

GENERAL TOLERANCE		制图	张迎春
X ₁ ±0.25	X ₂ ±2°	Mapping	2022、09、02
X ₃ ±0.25	X ₄ ±1°	审核	钱岳生
X ₅ ±0.15	X ₆ ±0.5°	批准	张名
XXX±0.10	XXX±0.5°	Approved	2022、09、03
Units	mm	比例	SCALE

料号: A15002-nAB
PART NO.
品名: ZH1.5立贴
TITLE
客户料号: WAFER SMT TYPE
CITM. NO.

版本: A
REV.

页次: 1/1
SHEET

乐清市宏一电子有限公司
YueQing HongYi Electronics Co., Ltd